

A photograph of the Impedans Moduli RF Event Detector, a non-invasive arc detection and pulse monitoring device. The device is a rectangular metal unit with a silver-colored top cover. The top cover features the Impedans logo, which consists of a stylized sunburst icon to the left of the word "Impedans" in a sans-serif font, with "PLASMA MEASUREMENTS" in smaller text below it. The device is mounted on a dark, textured surface, likely the interior of a metal cabinet or enclosure. The background is slightly blurred, showing the metallic structure of the enclosure.

Moduli RF Event Detector

Non-invasive Arc Detection and Pulse Monitoring

✓ <https://www.impedans.com/moduli-rf-event-detector/>

The Moduli Event Detector

Arc Detection and Pulse Monitoring

The Moduli Event Detector has two on-board algorithms that constantly process RF data with 1 microsecond resolution. The first is designed for detecting arcs within a plasma. The second monitors every single RF pulse and checks that each pulse is within the set specification

Parameters Measured:

- ✓ Voltage and current at the fundamental frequency
- ✓ Arcs ranging from sub-microsecond to 5000 microseconds long
- ✓ Categorizes arc types
- ✓ Pulse frequency, duty cycle
- ✓ Max, min, average pulse voltages and currents during the pulse-on time
- ✓ Checks every pulse for correct on time and cycle time, counts and reports "bad pulses"

Moduli Applications

- ✓ Quickly determine if arcing is the cause of an issue
- ✓ Pulse generator monitoring. Duty cycle deviations directly correlate with number of wafer defects, outside of a certain acceptable window
- ✓ Can sync with complex plasma recipes, changing its configuration automatically to monitor new pulse conditions and alarm appropriately for bad pulses
- ✓ It can automatically take regular "snapshots" of the pulses, reporting 5000 microseconds of pulses with 1 microsecond resolution
- ✓ Multi-level pulse monitoring

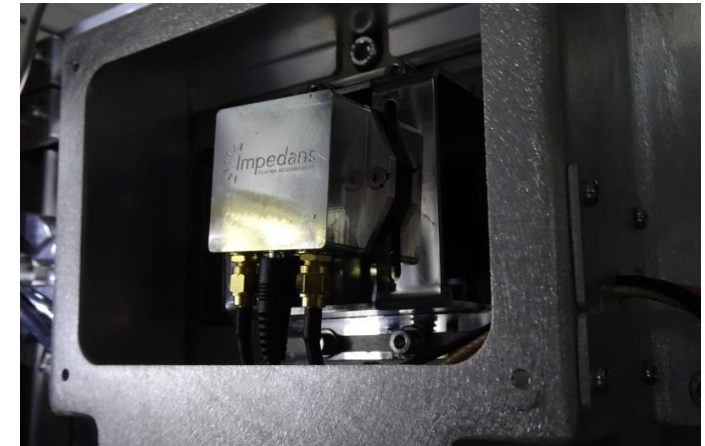

The Moduli RF Event Detector

Non-invasive Arc Detection and Pulse Monitoring

Non-invasive

- ✓ Can be installed on a plasma chamber window or close to the matchbox fan externally
- ✓ Can be installed inside a match box, but not in-line, so it's entirely non-intrusive
- ✓ Many APIs for easy tool integration
- ✓ Special antennas available for modern, shielded tools (100x sensitive, or Opto-RF)

Communication Protocols

- ✓ USB
- ✓ Ethernet
- ✓ Full APIs available for tool/factory integration
- ✓ Fully field upgradable

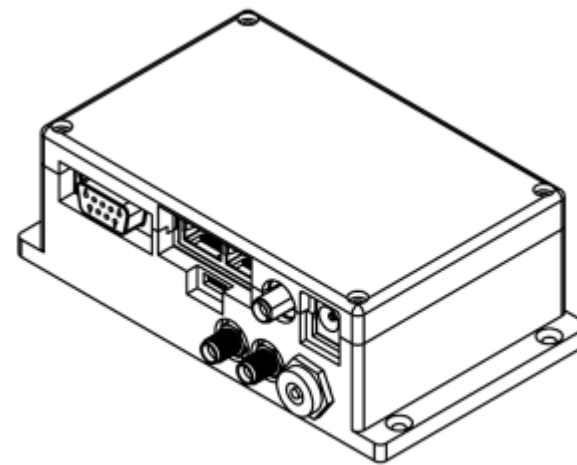
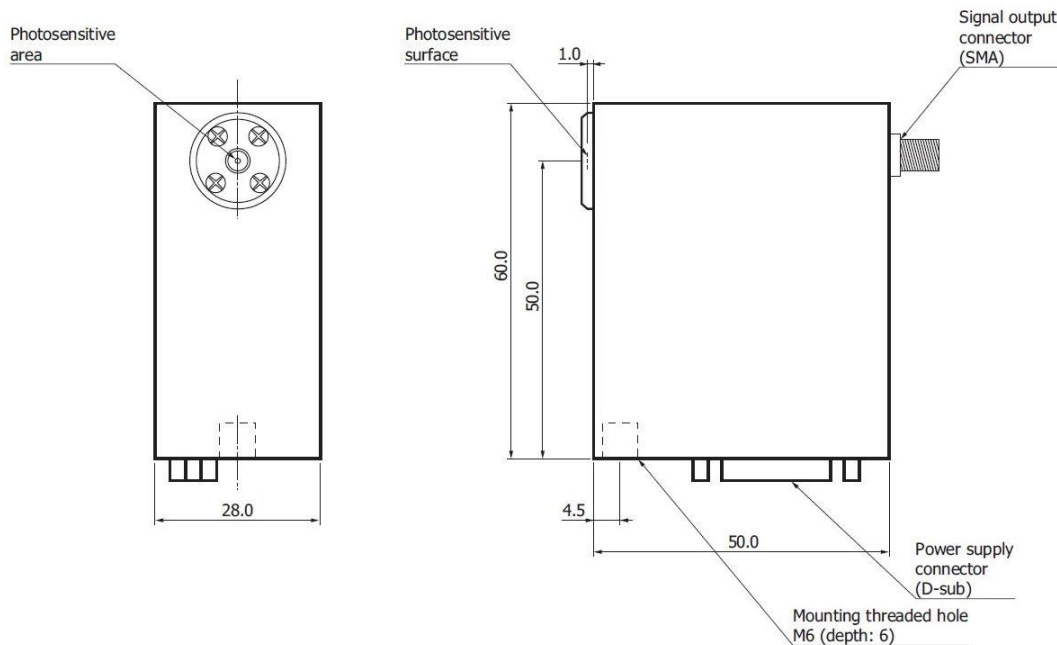

Isometric View

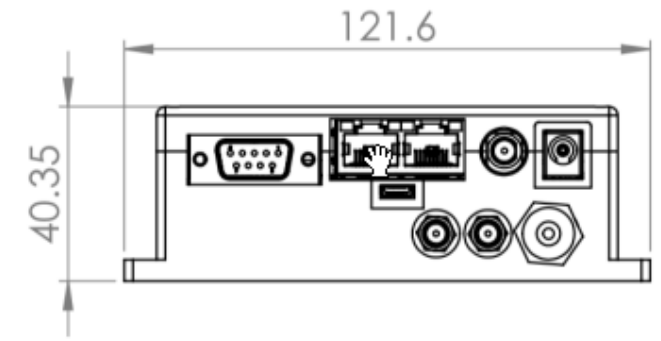

Front View

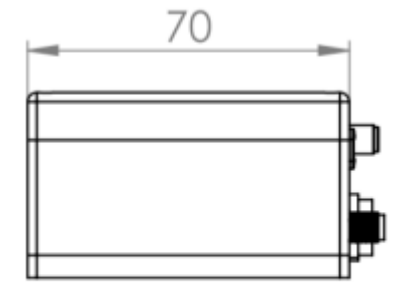

Side View

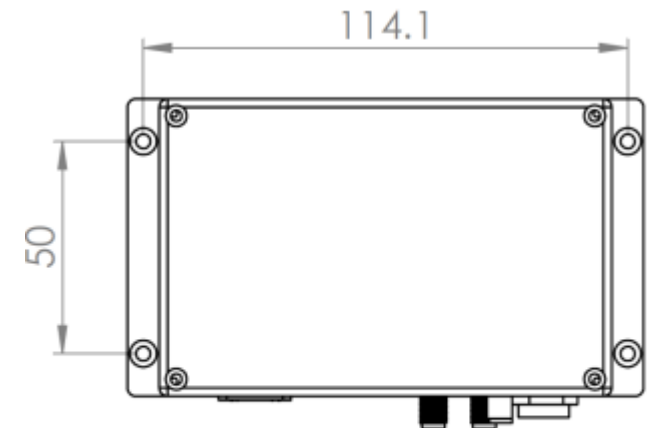

Plan View

Impedans

Key Features

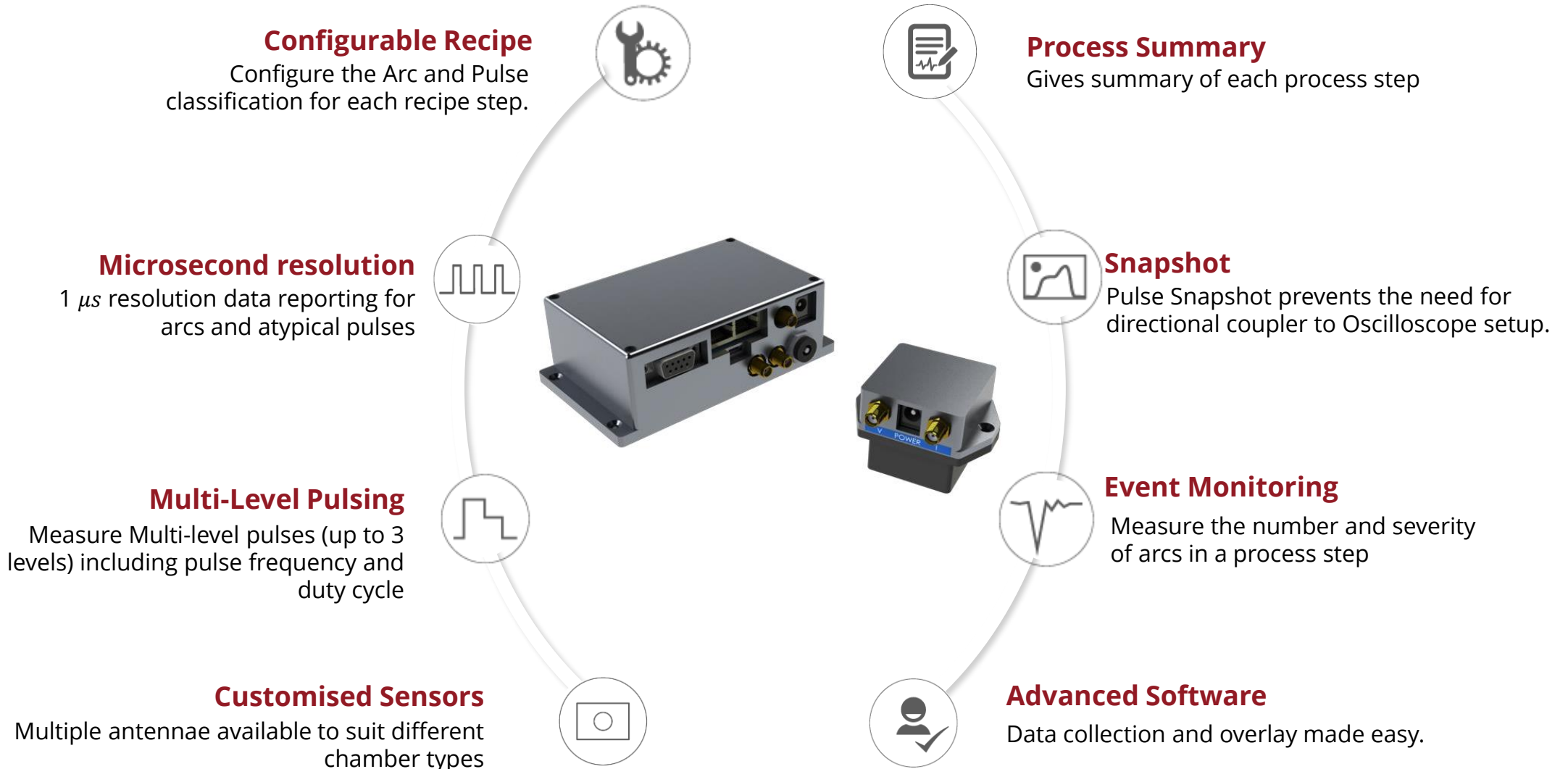

Technical Specifications

Parameters Measured	Range
Frequency Range	40 kHz → 400 kHz 350 kHz → 100 MHz
Output Parameters	V & I [UNCALIBRATED]
Pulsed RF Profiling	1 microsecond time resolution
In-Pulse Parameter Monitoring	Up to 2 points in the pulse [standard software], arbitrary number of points using API
Pulsed RF Range	10 Hz to 100 kHz
Pulse Timing Resolution	1 μs
Pulse Level Monitoring	Up to 3 levels (e.g. High - Low - Off)
Pulse Parameters Reported	Pulse Freq., Duty Cycle (of each level), Max & Min Pulse Voltage & Current, Pulse On Time, Pulse Period, number and percentage of incorrect pulses
Number of Recipe Steps	Max 40 Steps
Arc Duration Detection Range	1 – 5000 μs
Arc Amplitude Range (vs Moving average)	1% to 100%
Arc Categories	9 (3 time duration ranges x 3 amplitude change ranges)



- ✓ For more information, visit the Moduli Event Detector webpage here:
<https://www.impedans.com/moduli-rf-event-detector/>
- ✓ To arrange a technical discussion, contact support@impedans.com

Example Data: Arc Data

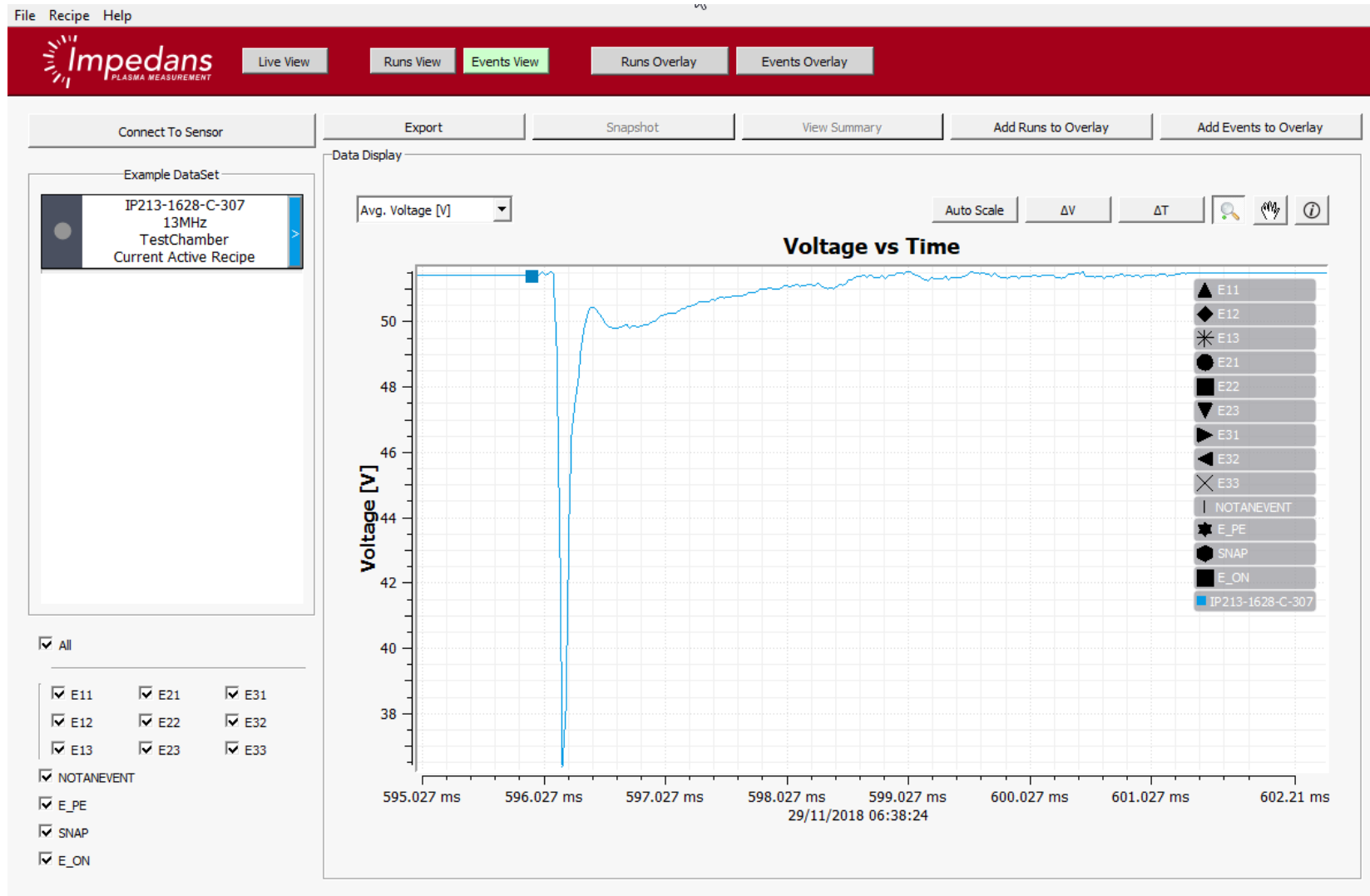

Example of Arc Data showing how the length of the arc is defined

Example Data: Pulse Data

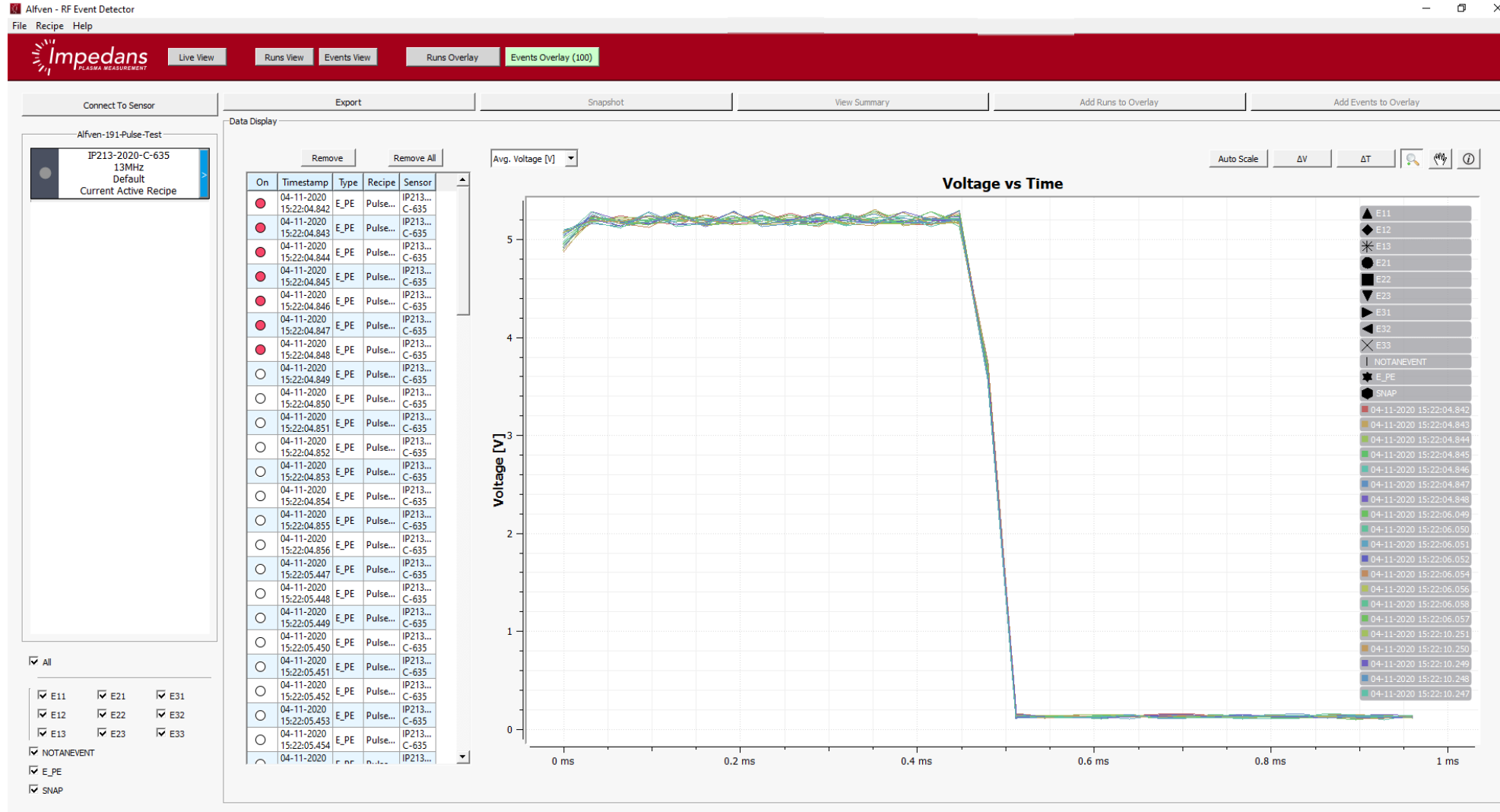

Example of a 1kHz 50% Duty Cycle Pulses overlaid to check for consistency

Example Data: Multi Level Pulse Data

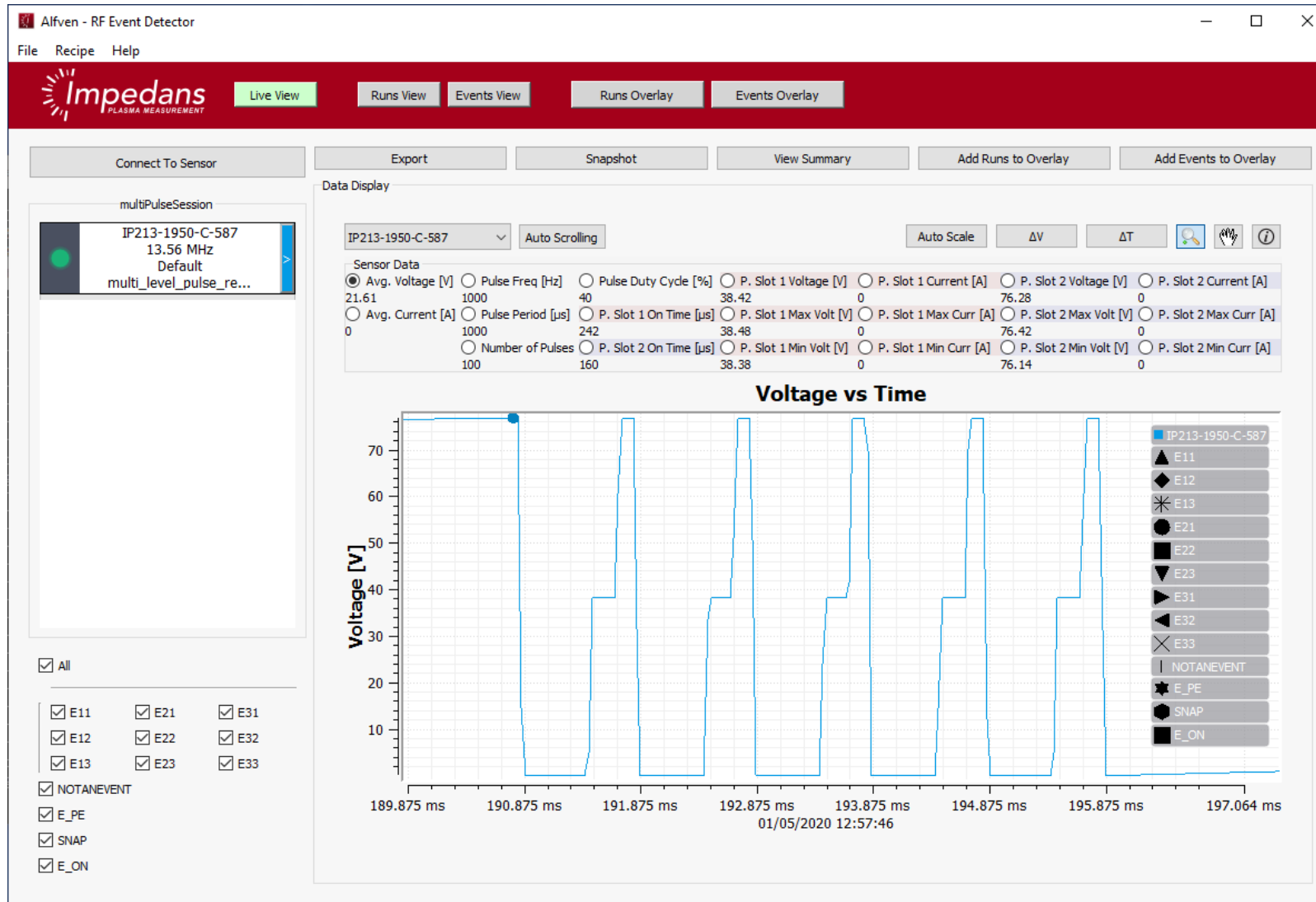

Example of a Low – High – Off multi level pulse.

Example Data: Multi Level Pulse Data

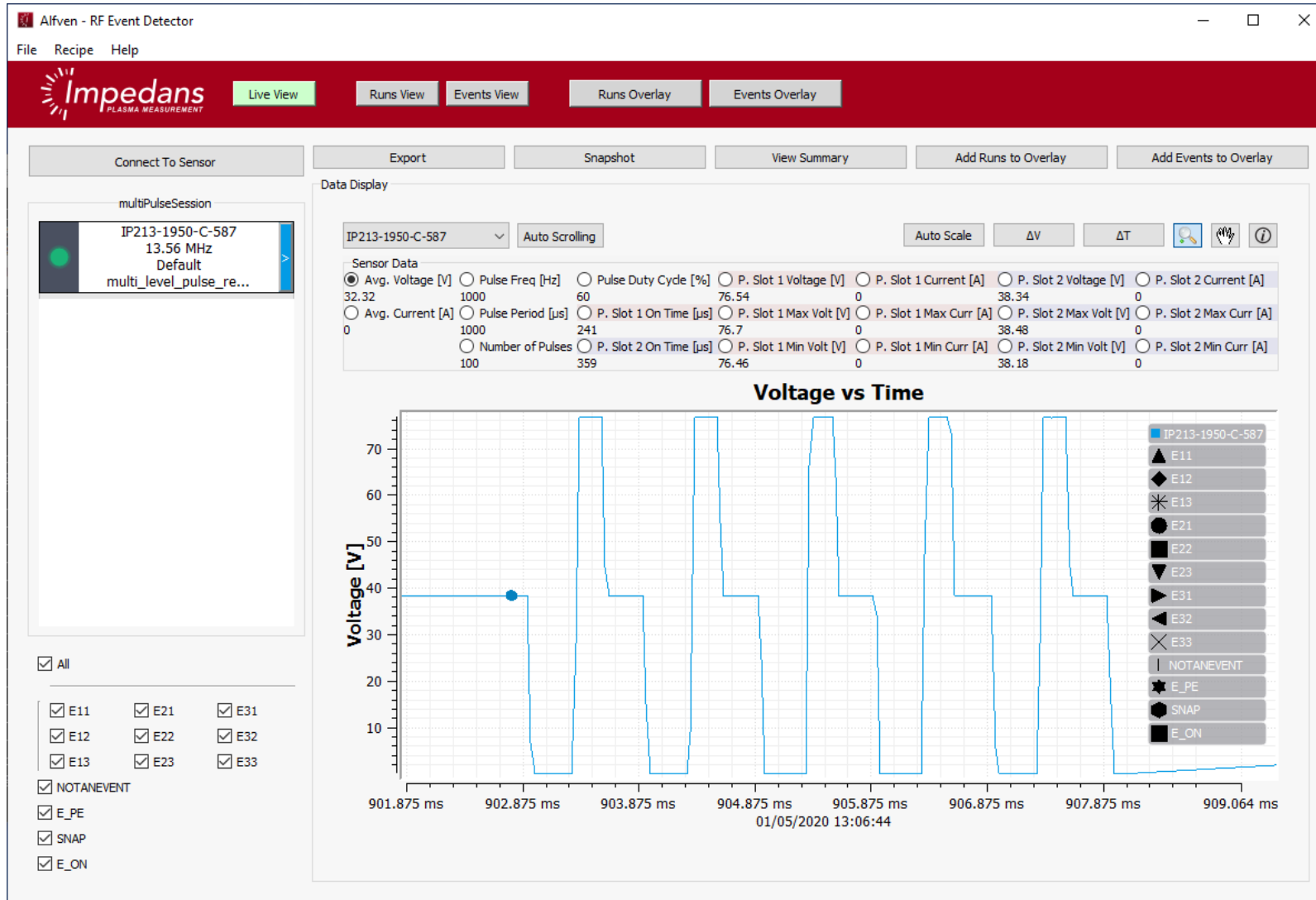

Example of a High - Low – Off multi level pulse.

Example Data: Live Parameter View

Sensor Data							
<input checked="" type="radio"/> Avg. Voltage [V]	<input type="radio"/> Pulse Freq [Hz]	<input type="radio"/> Pulse Duty Cycle [%]	<input type="radio"/> P. Slot 1 Voltage [V]	<input type="radio"/> P. Slot 1 Current [A]	<input type="radio"/> P. Slot 2 Voltage [V]	<input type="radio"/> P. Slot 2 Current [A]	
1.77	1000	50.3	3.38	0.05	0	0	
<input type="radio"/> Avg. Current [A]	<input type="radio"/> Pulse Period [μ s]	<input type="radio"/> P. Slot 1 On Time [μ s]	<input type="radio"/> P. Slot 1 Max Volt [V]	<input type="radio"/> P. Slot 1 Max Curr [A]	<input type="radio"/> P. Slot 2 Max Volt [V]	<input type="radio"/> P. Slot 2 Max Curr [A]	
0.0260192	1000	503	3.4	0.051	0	0	
	<input type="radio"/> Number of Pulses	<input type="radio"/> P. Slot 2 On Time [μ s]	<input type="radio"/> P. Slot 1 Min Volt [V]	<input type="radio"/> P. Slot 1 Min Curr [A]	<input type="radio"/> P. Slot 2 Min Volt [V]	<input type="radio"/> P. Slot 2 Min Curr [A]	
	100	0	3.36	0.05	0	0	

Example of the Live Data being shown in the Alfven Software

Example Data: Summary Report

Data Display

Export Auto export Summary successfully saved in C:/Users/broph/Documents/Test Data/30mHz_weekend_Test/summaries/2021-02-19_09-57-14_1kHz.csv

	Step Name	Duration [s]	Frequency [Hz]	Avg Voltage [V]	Avg Current [A]	Pulses	Pulse Period [μ s]	Pulse On Interval [μ s]	Duty Cycle [%]	Pulse Frequency [Hz]	Max Pulse 1 Voltage [V]	Min Pulse 1 Voltage [V]	Max Pulse 1 Current [A]	Min Pulse 1 Current [A]
1	1	20	13560000	1.78	0.0260192	99	999.517	502	50.2242	1000.48	3.4394	3.40179	0.051	0.000253731
2	2	20	13560000	1.78	0.0260192	100	999.51	502	50.2246	1000.49	3.4392	3.4022	0.051	0
3	3	20	13560000	1.7801	0.0260192	100	999.485	502	50.2259	1000.52	3.439	3.4008	0.051	0
4	4	20	13560000	1.78	0.0260192	100	999.475	502	50.2264	1000.53	3.4388	3.4013	0.051	0
5	Live Data	20	13560000	1.78	0.0260192	100	1000	502	50.2	1000	3.44	3.4	0.051	0.051

Data Display

Export Auto export Summary successfully saved in C:/Users/broph/Documents/Test Data/30mHz_weekend_Test/summaries/2021-02-19_09-57-14_1kHz.csv

	Max Pulse 1 Voltage [V]	Min Pulse 1 Voltage [V]	Max Pulse 1 Current [A]	Min Pulse 1 Current [A]	Max Pulse 2 Voltage [V]	Min Pulse 2 Voltage [V]	Max Pulse 2 Current [A]	Min Pulse 2 Current [A]	Bad Pulses [%]	E11	E12	E13	E21	E22	E23	E31	E32	E33	E_PE
1	3.4394	3.40179	0.051	0.000253731	0	0	0	0.000253731	1.0101	0	0	0	0	0	0	0	0	0	1
2	3.4392	3.4022	0.051	0	0	0	0	0	0	0	0	0	0	0	0	0	0	0	0
3	3.439	3.4008	0.051	0	0	0	0	0	143	0	0	0	0	0	0	0	0	0	143
4	3.4388	3.4013	0.051	0	0	0	0	0	20000	0	0	0	0	0	0	0	0	0	20000
5	3.44	3.4	0.051	0.051	0	0	0	0.051	100	0	0	0	0	0	0	0	0	0	100

Example of the Recipe Summary using a multi-step recipe that included pulsing with finer acceptance levels in each step (100, 50, 10 and 1 μ s for Pulse Period and the Pulse on-time)

Example Data: Event Overlay

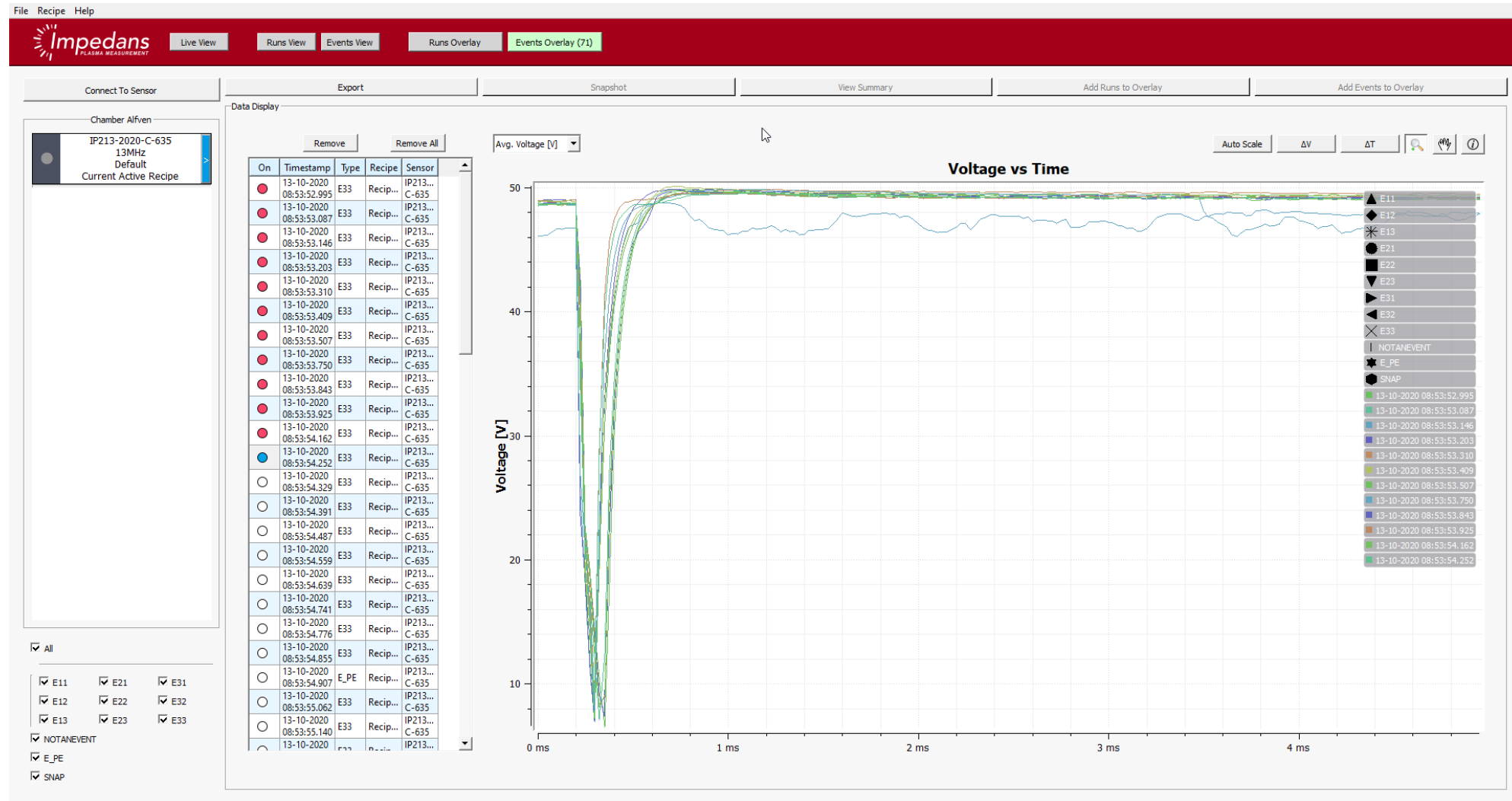

Example of Arc Data showing E33 (severe) Arcs overlaid.

Example Data: Run Overlay

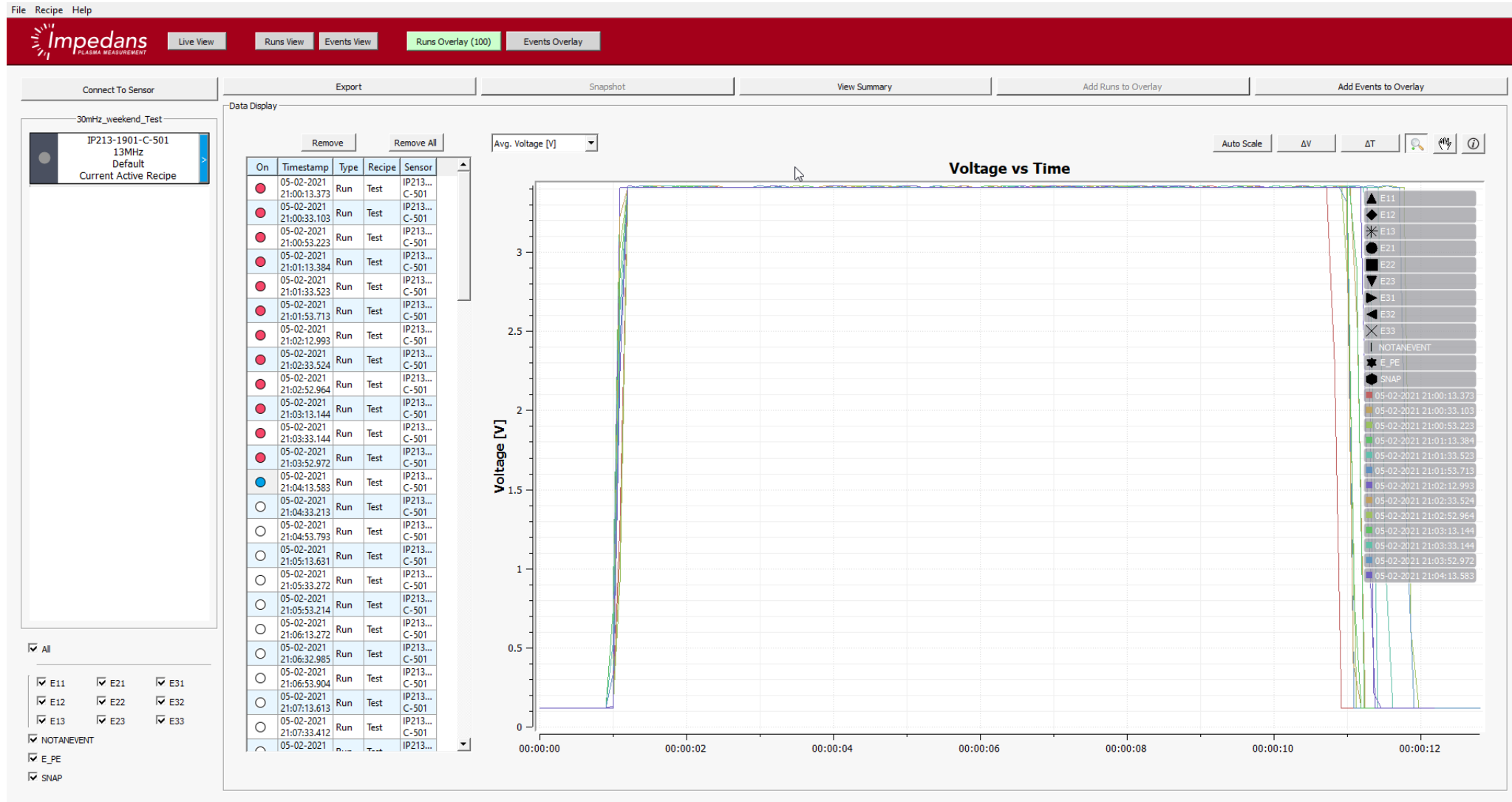

Example of Run Data being overlaid to check for consistency of processes

Example Data: Recipe Creation

Recipe Form

Recipe Name: 1kHz Pulse Load Recipe

Step Name: 25% Duty

Step Duration: 10 sec

Step RF Frequency: 13560 KHz

Skip Time At Start: 1 sec

Multilevel Pulse Threshold: 0 (Disabled)

Noise Filter Length: 32 μ s

Enable Strike Event:

RF On - Off Switch Time: 3000 ms

Enable Auto Snapshot:

Delay After Each Step: 1000 ms

Number of Snapshots: 1

Minimum Event Amplitude: 50 μ s, 100 μ s, 500 μ s

Maximum Event Length: 100 μ s, 500 μ s

Enable Pulse Event:

Pulse Frequency: 1000 Hz (1000 μ s)

Pulse Duty Cycle: 25 % (Ton = 250 μ s)

Pulse Period Error Margin: 10 μ s (990~1010 μ s)

Duty Cycle Error Margin: 5 μ s (245~255 μ s)

Pulse Event Resolution: 1 μ s

	Name	Duration[s]	Frequency[Hz]	Skip time[s]	Threshold[V]	MEL1[μ s]	MEL2[μ s]	MEL3[μ s]	MEA1[%]	MEA2[%]	MEA3[%]
1	CW	10	13560000	1	0	50	100	500	10	20	50
2	25% Duty	10	13560000	1	0	50	100	500	10	20	50

Save Recipe Close

Example of the Creation of a Multi-Step recipe

Arc Management

Causes of arcs - 1) Poor Chamber Seasoning

- ✓ If chamber seasoning is incomplete, then some areas of the wall will be conducting and other parts insulating
- ✓ Or, if the coating is uneven, then in some areas the coating will be thin enough for breakdown to eventually occur through the dielectric material to the wall
- ✓ This type of arc is responsible for particle creation
- ✓ Aluminium particles are sputtered from the wall. These metal clusters collect many electrons, becoming "super-negative ions". These particles collect above the plasma sheath, just above the wafer.
- ✓ When the plasma is off, they fall onto the wafer and will contaminate the next layer.

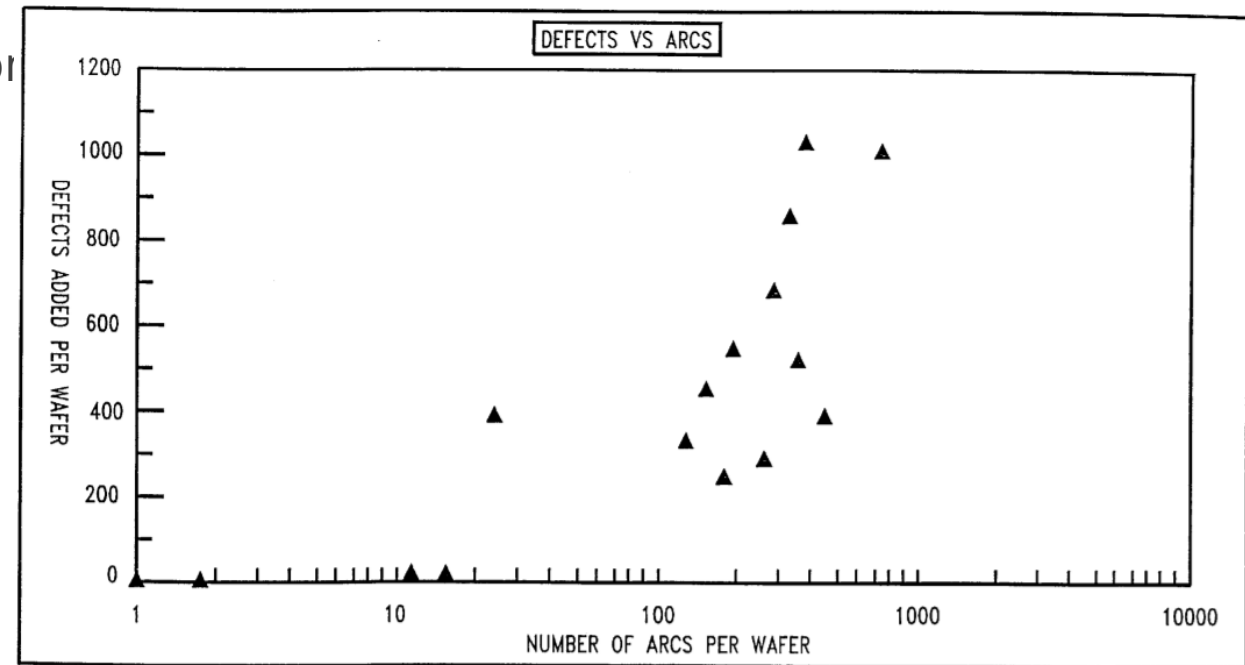
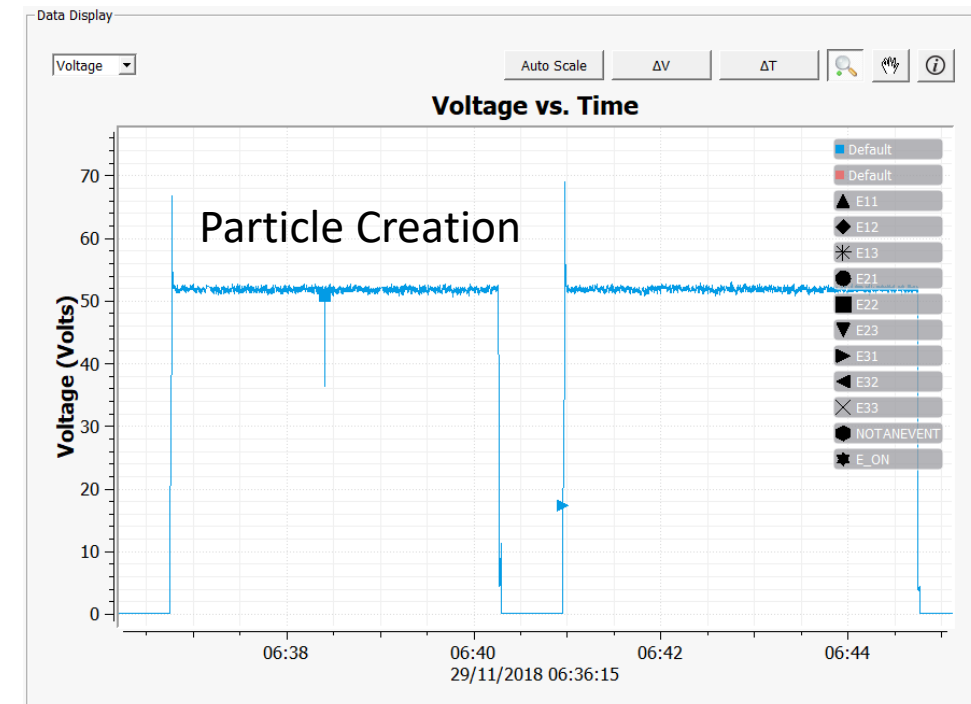

Figure ref: US Patent US5993615A 1999-11-30 Method and apparatus for detecting arcs

Causes of arcs - 1) Poor Chamber Seasoning

- ✓ The example in the graph was from a PECVD chamber with poor seasoning. It took multiple dummy wafers before it was allowed to run product, so the chamber would become correctly conditioned (multiple cycles)
- ✓ There are a few possible solutions
 - A. Increase the duration of the seasoning step so the chamber is well coated. This may require an increase in the cleaning step duration.
 - B. Introduce a pre-seasoning step, like an extra cleaning process. This is especially needed after the chamber has been opened, since there may be some water vapour on the surfaces
 - C. To purge a system of left-over metal particles, put in a dummy wafer and run high gas flows for a few minutes. The particles will flow out of the system or be collected by the dummy wafer surface.



Causes of arcs - 2) Poor Grounding

- ✓ Poor grounding covers a number of arc causes
 - A. Poor chamber chassis earth connection. This will cause the chamber to “float” to a certain voltage near the plasma potential due to charge build-up. This charge will dissipate at random, causing arcing.
 - B. Poor wafer contact with the chuck, or poor wafer clamping.
 - ✓ This is particularly critical when a conducting layer is being deposited on an insulating layer. Charge will build up on the insulating layer until it breaks down to the nearest conducting surface (which may be through to a lower layer in the wafer itself).
- ✓ Preventing these from happening simply requires good chamber maintenance.
 - ✓ Be aware that invisible oxide layers build up on the surface of metals in the chamber.
 - ✓ Connections to ground should be scrubbed free of oxides. RF travels on the surface of metals (“skin depth”), so clean the surface of ground connectors before attaching them.
 - ✓ Check braiding for damage and replace if necessary.

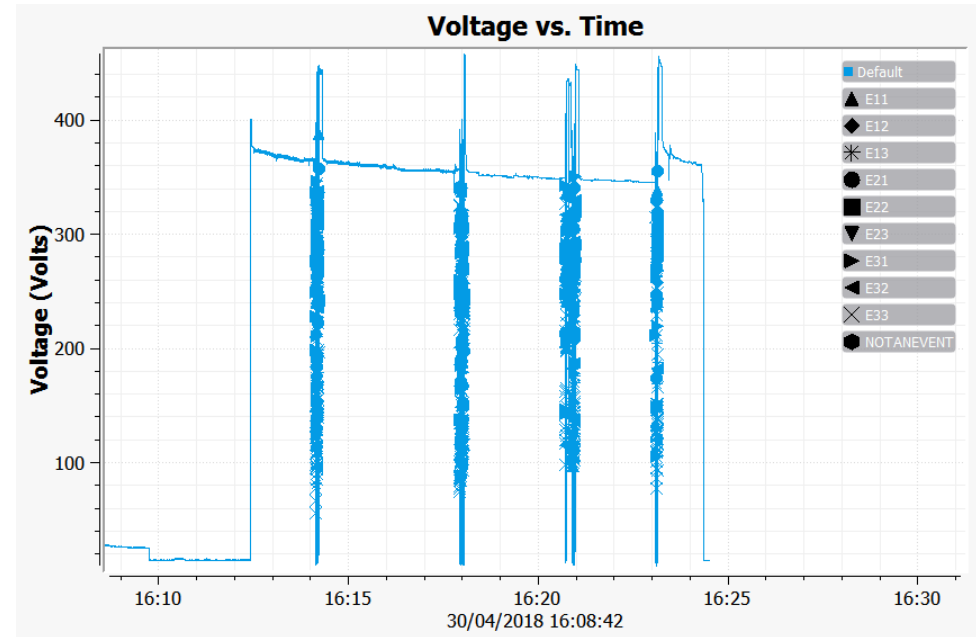

Causes of arcs - 3) Generator and Match Box

- ✓ Arcs can also be caused by faulty parts in the RF network.
- ✓ One example is this situation where products had burn marks if they were left in the chamber for too long after processing. If the product was removed immediately, there was never any damage
- ✓ It was discovered that the generator was randomly outputting power even when the dial reading was zero – this was due to a faulty relay switch.
- ✓ Power would come on for a few hundred microseconds, causing thousands of volts across the wafer. The “ringing” in the microsecond data is typical of a power supply relay switch.
- ✓ A similar “ringing” with high voltages can be seen when the match box begins to fail. Arcs inside the match box capacitors cause very brief spikes in reflected power, which have an oscillating shape

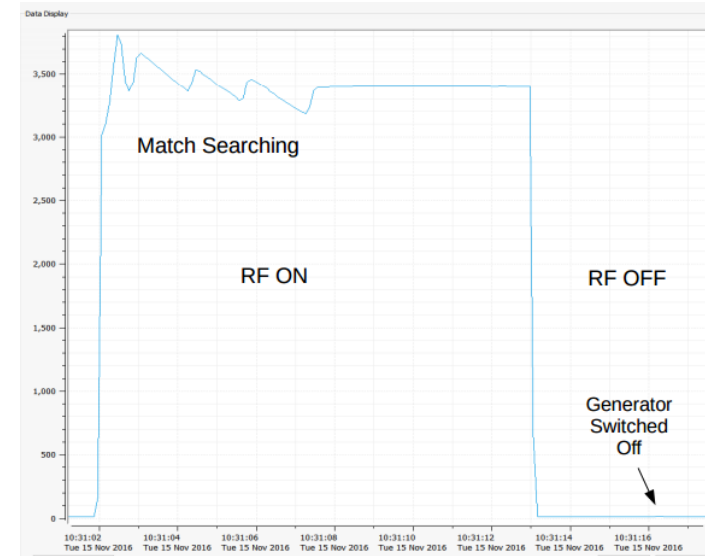

Alfven spots that the RF output comes on back on for 400us while generator powers down. (RF is off)

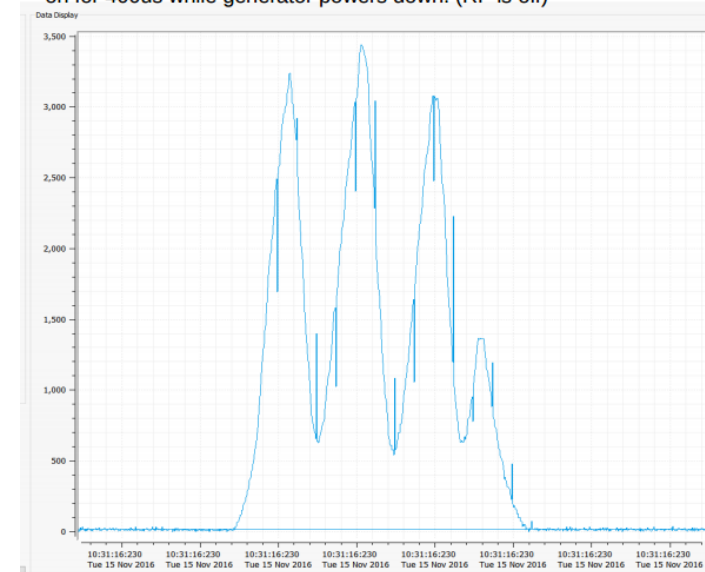

Impedans Ltd

Chase House, City Junction Business Park, Northern Cross,
Dublin 17, D17 AK63, Ireland

Ph: +353 1 842 8826

Fax: +353 1 871 2282

Web: www.impedans.com

Email: support@impedans.com

